

Miele

Operating and installation instructions

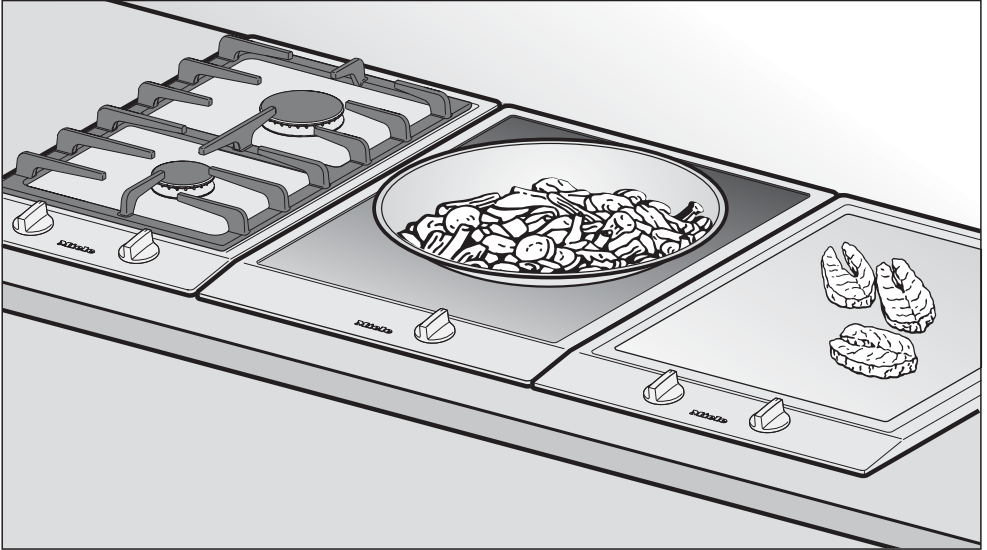

Gas hobs CS 1012-1 CS 1034-1

To avoid the risk of accidents or damage to the appliance it is **essential** to read these instructions before it is installed and used for the first time.

en - GB

M.-Nr. 09 094 640

-
- (D)** Das Gerät ist auch für den Gebrauch in anderen als auf dem Gerät angegebenen Bestimmungsländer zugelassen. Die landesspezifische Ausführung und die Anschlussart des Gerätes haben wesentlichen Einfluss auf den einwandfreien und sicheren Betrieb. Für den Betrieb in einem anderen als auf dem Gerät angegebenen Bestimmungsland wenden Sie sich bitte an den für das Land zuständigen Kundendienst.
- (E)** El aparato está autorizado para el uso en países diferentes a los países de destino indicados. La ejecución específica para cada país y el tipo de conexión del aparato influyen de forma decisiva en el funcionamiento correcto y seguro. Para el funcionamiento en un país diferente al país de destino indicado en el aparato, consulte al Servicio Post-venta autorizado para el país.
- (F)** Cet appareil est également homologué dans des pays différents de ceux mentionnés sur l'appareil. Pour que l'appareil fonctionne parfaitement et en toute sécurité, il est important de disposer de l'exécution spécifique au pays et du type de raccordement approprié. Pour le fonctionnement dans un pays autre que celui spécifié sur l'appareil, veuillez vous adresser au service après-vente du pays où sera installé l'appareil.
- (GB)** This appliance can be used in countries other than those specified on the appliance. It is, however, set up for connection to the gas and electricity supplies in the countries specified. For use in other countries please contact the Miele spare parts or customer service department in your country.
- (I)** L'apparecchio può essere usato anche in paesi diversi da quello indicato sull'apparecchio stesso. Tuttavia, le varianti specifiche di un determinato paese e il tipo di allacciamento alla rete hanno un'importanza fondamentale per il suo sicuro e corretto funzionamento. Per questo se si vuole usare l'apparecchio in un paese diverso rivolgersi al servizio di assistenza tecnica Miele del paese in cui si intende usarlo.
- (NL)** Het apparaat is ook toegelaten voor gebruik in andere landen dan de landen die op het apparaat vermeld staan. De specifieke uitvoering en de aansluitwijze zijn van groot belang voor het goed en veilig functioneren. Neem daarom contact op met de Technische Dienst van de fabrikant in uw land als u het apparaat in een land wilt gebruiken dat niet op het apparaat vermeld staat.

Guide to the appliance	6
CS 1012-1	6
CS 1034-1	7
Warning and Safety instructions	9
Caring for the environment	20
Before using for the first time	21
Operation	22
Rapid ignition system	22
Switching on, adjusting the flame and switching off	22
In-operation indicator and Residual heat indicator	24
Suitable pans	25
Energy-saving tips	26
Safety features	27
Cleaning and care	28
Stainless steel surfaces	29
Pan supports, control knobs	29
Burner	30
Problem solving guide	31
Optional accessories	33
Safety instructions for installation	34
Appliance and building-in dimensions	38
CS 1012-1	38
CS 1034-1	39

Contents

Preparing the worktop	40
Installation of several appliances	41
Fixing the spring clamps and spacer bars	43
Installing / removing the appliance	45
General installation tips	46
Electrical connection	47
Gas connection	49
Conversion to another type of gas	51
CS 1012-1	51
Jet table	51
CS 1034-1	52
Jet table	52
Changing the jets	53
Function test	54
After sales service, data plate, guarantee	55

Gas-heated appliances

Safety precautions to take if you smell gas

- Turn off the gas emergency control valve immediately.
This is usually located near the gas meter.
- Eliminate all sources of ignition in a safe manner.
Do not smoke, light cigarette lighters or matches.
- Do not operate electrical lights or switches, i.e. do not switch them "On" or "Off".
- Open all doors and windows to ventilate the area.
- If the smell of gas persists, evacuate the building.

In the UK you must now:

- Call the Gas Emergency Contact Centre (Tel: 0 800 111 999)

For any gas work in the UK always use a Gas Safe registered engineer.



In other countries please follow relevant country specific procedures on gas.

Guide to the appliance

CS 1012-1

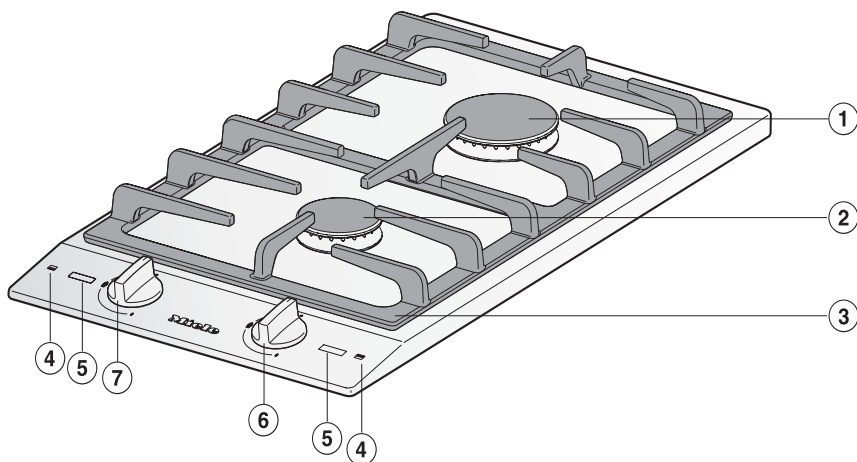

① Large burner

② Medium burner

③ Pan support

④ Symbols to indicate which gas burner the control is for

⑤ Display

Controls:

⑥ rear

⑦ front

Display



⑫ In-operation indicator

⑬ Residual heat indicator

CS 1034-1

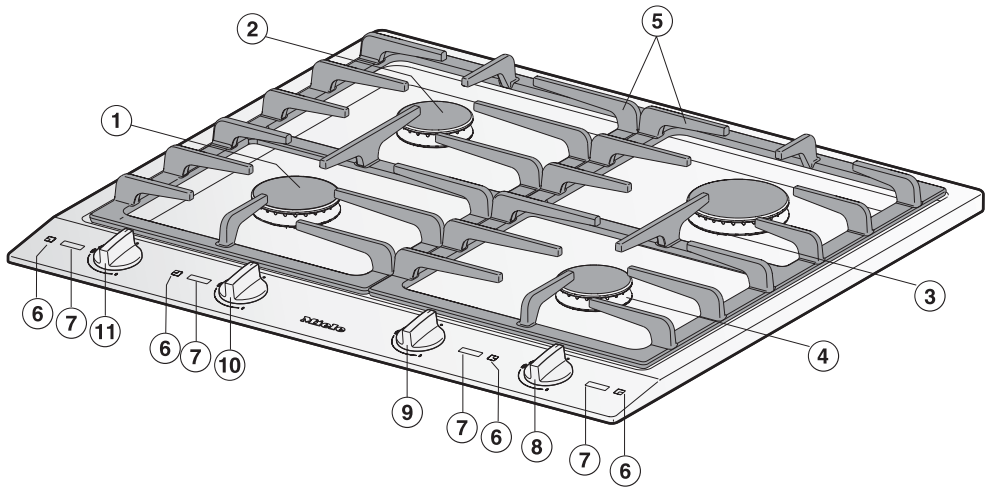

- ① Large burner
 - ② Small burner
 - ③ Large burner
 - ④ Medium burner
 - ⑤ Pan supports
 - ⑥ Symbols to indicate which gas burner the control is for
 - ⑦ Display
- Controls:
- ⑧ front right
 - ⑨ rear right
 - ⑩ rear left
 - ⑪ front left

Display

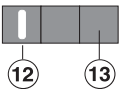

- ⑫ In-operation indicator
- ⑬ Residual heat indicator

Guide to the appliance

Burner

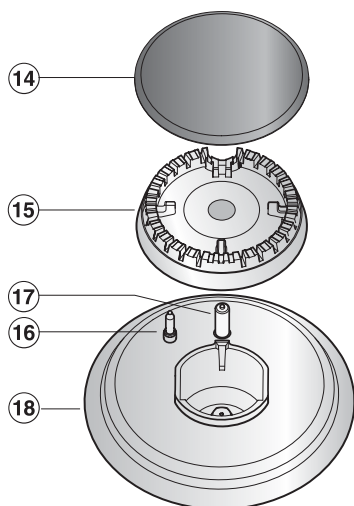

- ⑭ Burner cap
- ⑮ Burner head
- ⑯ Ignition safety device
- ⑰ Ignitor
- ⑱ Burner base

Warning and Safety instructions

This appliance complies with all current local and national safety requirements. Improper use can, however, present a risk of both personal injury and material damage.

To avoid the risk of accidents and damage to the appliance, please read these instructions carefully before installation and before using it for the first time. They contain important notes on installation, safety, use and maintenance.

Keep these instructions in a safe place and ensure that new users are familiar with the content. Pass them on to any future owner.

Warning and Safety instructions

Correct application

▶ This hob is not designed for commercial use. It is intended for use in domestic households and in similar working and residential environments such as:

- Shops
- Offices and showrooms

and by residents in establishments such as:

- Hostels and guest houses.

▶ The hob is intended for domestic use only to cook food and keep it warm.

Any other use is not supported by the manufacturer and could be dangerous. Miele cannot be held liable for damage resulting from incorrect or improper use or operation.

▶ The hob is not intended for outdoor use.

▶ The hob can only be used by people with reduced physical, sensory or mental capabilities or lack of experience and knowledge if they are supervised whilst using it, or have been shown how to use it in a safe way and understand the hazards involved.

Safety with children

- ▶ The hob is not a toy! To prevent the risk of injury, do not let children play with the appliance or its controls.
- ▶ Children under 8 years of age must be kept away from the hob unless they are constantly supervised.
- ▶ Children 8 years and older may use the hob only if they have been shown how to use it in a safe way and understand the hazards involved.
- ▶ The hob gets hot when in use and remains hot for quite a while after being switched off. Keep children well away from the appliance until it has cooled down and there is no danger of burning.
- ▶ Do not store anything which might arouse a child's interest in storage areas above or next to the hob. Otherwise they could be tempted into climbing onto the appliance with the risk of burning themselves.
- ▶ Keep all pans out of reach of children. Turn pan handles inwards away from the edge of the hob. Danger of burning or scalding.
- ▶ Packaging, e.g. cling film, polystyrene and plastic wrappings, must be kept out of the reach of babies and young children. Danger of suffocation. Dispose of or recycle all packaging safely as soon as possible.

Warning and Safety instructions

Technical safety

- ▶ Before installation, check the hob for visible signs of damage. Do not install and use a damaged appliance. It could be dangerous.
- ▶ The electrical safety of the hob can only be guaranteed if correctly earthed. It is most important that this basic safety requirement is observed and regularly tested, and where there is any doubt, the household wiring system should be inspected by a qualified electrician.
Miele cannot be held liable for the consequences of an inadequate earthing system (e.g. electric shock).
- ▶ Before connecting the hob to the mains electricity supply, make sure that the data quoted on the data plate match the household mains supply, otherwise the appliance could be damaged. Consult a qualified electrician if in any doubt.
- ▶ For safety reasons, the hob may only be used after it has been built in.
- ▶ Do not open the casing of the hob.
Tampering with electrical connections or components and mechanical parts is highly dangerous to the user and can cause operational faults.

Warning and Safety instructions

▶ Connection to the gas supply must be carried out by a suitably qualified and competent person in strict accordance with current local and national safety regulations, e.g. a **Gas Safe** registered technician in the U.K.



The hob may be connected via a fused plug and switched socket. If you wish to connect it to a fused spur connection, or if the appliance is supplied without a plug, it must be installed and connected to the electrical supply by a suitably qualified and competent person in strict accordance with current local and national safety regulations. Miele cannot be held liable for damage caused by incorrect installation or connection.

▶ Installation, maintenance and repairs may only be carried out by a suitably qualified and competent person in strict accordance with current national and local safety regulations.

Repairs and other work by unqualified persons could be dangerous. Miele cannot be held liable for unauthorised work.

Warning and Safety instructions

- ▶ During installation, maintenance and repair work, the hob must be disconnected from the gas supply and mains electricity supply.
- ▶ While the hob is under guarantee, repairs should only be undertaken by a service technician authorised by Miele. Otherwise the guarantee is invalidated.
- ▶ Faulty components must only be replaced by genuine Miele original spare parts. The manufacturer can only guarantee the safety of the appliance when Miele replacement parts are used.
- ▶ If the connection cable is damaged, it must be replaced by a suitably qualified electrician with a special connection cable of type H 05 V V-F (pvc insulated), available from Miele.
- ▶ The hob is not intended for use with an external timer switch or a remote control system.
- ▶ Do not connect the hob to the mains electricity supply by a multi-socket adapter or an extension lead. These do not guarantee the required safety of the appliance (e.g. danger of overheating).
- ▶ Do not use the hob if it is faulty. Switch it off immediately and disconnect it from the mains electricity supply and the gas supply. Call the Service Department.

Warning and Safety instructions

▶ In areas which may be subject to infestation by cockroaches or other vermin, pay particular attention to keeping the appliance and its surroundings clean at all times. Any damage which may be caused by cockroaches or other vermin will not be covered by the guarantee.

Correct use

▶ The hob gets hot when in use and remains hot for quite a while after being switched off. Do not touch it whilst it could still be hot.

▶ If a cooker hood is installed above the hob, ensure that the burners are always covered with a pan when in use. Otherwise flames could reach the cooker hood, parts of which could then be damaged or set on fire.

▶ Do not leave the hob unattended whilst it is being used. Oil and fat are potential fire hazards as they can ignite if overheated.

▶ If oil or fat does catch fire, do not attempt to put out the flames with water. Use a suitable fire blanket, saucepan lid, damp towel or similar to smother the flames.

▶ Do not use the hob to heat up the room. Due to the high temperatures radiated, objects near the appliance could catch fire. The life of the appliance could also be reduced.

Warning and Safety instructions

- ▶ Use heat-resistant pot holders or gloves when using the hob. Ensure that they do not come into contact with the flames. Do not use large cloths, tea towels or similar as the ends could touch the flames and catch fire. Do not let the gloves get damp or wet, as this causes heat to transfer through the material more quickly with the risk of scalding or burning yourself.
- ▶ Do not flambé under a cooker hood. The flames could set the cooker hood on fire.
- ▶ Do not use the hob as a resting place for anything. When the appliance is switched on either deliberately or by mistake, or when there is residual heat present, the article could melt or catch fire.
- ▶ Where several appliances are installed side by side
Do not place hot pots or pans on the cover strip as this can damage the seal.
- ▶ Do not cover the hob, e. g. with a hob cover, a cloth or protective foil. The material could catch fire, shatter or melt if the appliance is switched on by mistake or if it is still warm.
- ▶ Do not use plastic or aluminium foil containers. These melt at high temperatures and could catch fire.
- ▶ Do not heat up unopened tins of food on the hob, as pressure will build up in the tin, causing it to explode. This could result in injury and scalding or damage.

Warning and Safety instructions

- ▶ Make sure all the components of the gas burners have been correctly assembled before switching on.
- ▶ Pans must be the correct size for the burner they are used on (see "Suitable pans"). A pan which is too small will be unstable on the pan support. If the pan diameter is too large, flames can spread out to the sides and damage or burn the worktop, wall claddings or surrounding units and also parts of the hob. Miele cannot be held liable for this type of damage.
- ▶ Ensure that the flames from the burner do not spread out beyond the base and up the sides of the pan.
- ▶ Unless the pan manufacturer states that you can do so, do not use pans with very thin bases on the hob, and never heat up empty pans as they could get damaged. This could also damage the appliance.
- ▶ The pan support supplied must always be used. Pans must not be placed directly on the burner.
- ▶ Do not store any inflammable objects near the hob.
- ▶ Remove splashes of fat and other food debris from the surface as soon as possible. These are a fire hazard.
- ▶ Replace the pan supports carefully to avoid scratching the surface of the hob.

Warning and Safety instructions

- ▶ Using the hob will cause a build-up of heat and moisture in the room in which it is installed. Ensure that the room has sufficient natural or mechanical means of ventilation, e.g. an extractor.
- ▶ If the hob is used for very long periods of time additional ventilation of the room may be necessary, e.g. by opening windows or doors, or running the extractor on the highest setting.
- ▶ When using an electrical appliance, e.g. a hand-held food blender, near the hob, ensure that the cable of the electrical appliance does not come into contact with the hot hob. The insulation on the cable could become damaged, giving rise to an electric shock hazard.
- ▶ Spray canisters, aerosols and other inflammable substances must not be stored in a drawer under the hob. Cutlery inserts must be heat-resistant.
- ▶ Always ensure that food is sufficiently cooked or reheated. Some foods may contain micro-organisms which are only destroyed by thorough cooking at a sufficiently high temperature for long enough. Therefore, when cooking or reheating food such as poultry, it is particularly important that the food is completely cooked through. If in doubt, select a longer cooking or reheating time.

Warning and Safety instructions

- ▶ Avoid allowing liquids or foods containing salt to spill onto the hob. If salty foods or liquids do get on the hob, they should be removed as soon as possible to avoid the risk of corrosion.
- ▶ If the hob is installed behind a kitchen furniture door, it may only be used with the furniture door open. Only close the door when the appliance is switched off and the residual heat indicators have gone out.
- ▶ If the hob has not been used for a long period of time it should be thoroughly cleaned before it is used again. It is also advisable to have the appliance tested for safety.

Miele cannot be held liable for damage caused by non-compliance with these Warning and Safety instructions.

Caring for the environment

Disposal of the packing material

The transport and protective packing has been selected from materials which are environmentally friendly for disposal, and should be recycled.

Ensure that any plastic wrappings, bags, etc. are disposed of safely and kept out of the reach of babies and young children. Danger of suffocation.

Disposal of your old appliance

Electrical and electronic appliances often contain materials which, if handled or disposed of incorrectly could be potentially hazardous to human health and to the environment. They are, however, essential for the correct functioning of your appliance. Please do not therefore dispose of it with your household waste.

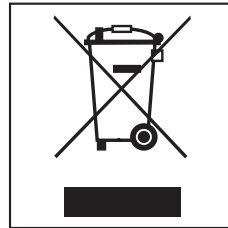

Please dispose of it at your local community waste collection/recycling centre or contact your dealer for advice. Ensure that it presents no danger to children while being stored for disposal.

Please stick the extra data plate for the appliance supplied with this documentation in the space provided in the "After sales service, data plate, guarantee" section of this booklet.

Cleaning for the first time

- Remove any protective foil and stickers.
- Clean all removable parts of the burners with a solution of warm water and a little washing-up liquid applied with a soft sponge. Dry all parts thoroughly after cleaning and then reassemble the burners (see "Cleaning and care").
- Clean the stainless steel trough with a damp cloth, and then wipe dry.

Metal components have a protective coating which may give off a slight smell when heated up for the first time.

The smell and any vapours will dissipate after a short time, and do not indicate a faulty connection or appliance.

Operation

Rapid ignition system

The appliance is supplied with a rapid ignition system with the following features:

- Rapid ignition without pressing and holding the control
- Automatic re-ignition

Should the flame be extinguished by a gust of air, the burner will re-ignite automatically.

If re-ignition is unsuccessful, the gas supply will be cut off automatically (see "Safety cut-off").

Switching on, adjusting the flame and switching off

The control is used to ignite the burner and to regulate the strength of the flame.

- The gas supply is turned off

⬆ Strong flame

⬆ Weak flame

The burners can only be switched on by pressing in the appropriate control and turning it anti-clockwise, and switched off by turning the control clockwise.

The following will **cause damage** to the appliance:

- Switching the burner on without pressing the control down,
- Switching the burner on by turning the control clockwise,
- Switching the burner off by turning the control anti-clockwise.

The manufacturer will not accept liability for any damage resulting from incorrect operation.

Switching on

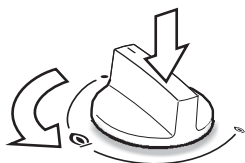

- To ignite the burner press the control knob down and turn it anti-clockwise to the large flame symbol. The ignitor will make a clicking sound and ignite the gas.

Operating a control will automatically create a spark on every burner. This is quite normal and does not indicate a fault.

If the burner does not ignite, turn the control to off "●". Air the room or wait at least 1 minute before trying again.

If the burner does not ignite the second time, turn the control to "●", and see "Problem solving guide".

When switching on, re-ignition sometimes occurs (1-2 clicks) if the flame on the ignition safety device has gone out briefly, or if the thermal element is not hot enough, e.g. following a gust of air.

Regulating the flame

The burners can be regulated at any level between the strongest and weakest flame.

Control the flame so that it does not spread out beyond the sides of the pan. As the outer part of the flame is much hotter than the centre, the tips of the flames should stay beneath the pan base. Flame tips which extend beyond the sides of the pan merely warm up the air in the room and can also damage pan handles and increase the danger of injury.

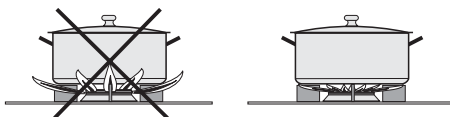

Switching off

- Turn the control clockwise to position "●".

This stops the flow of gas and the flame goes out.

Operation

In-operation indicator and Residual heat indicator

When a gas burner is switched on, the relevant in-operation indicator lights up. Once it has reached a certain temperature, the residual heat indicator also lights up. The in-operation indicator goes out when the gas burner is switched off. The residual heat indicator remains on until the gas burner is cool enough to touch.

Do not touch or place any heat sensitive objects on the gas hob while the residual heat indicator is still on. Danger of burning and fire.

If the displays are flashing, this shows there is a fault. See section "Problem solving guide".

Suitable pans

Burner	Min. pan base diameter in cm
Small burner	10
Medium burner	12
Large burner	14
	Max. diameter at top of pan in cm
Small burner	20
Medium burner	22
Large burner	24

- Refer to the chart above and ensure that the pan diameter falls within the minimum and maximum diameters given for the burner you are using. A pan which is too small will be unstable on the pan support. If the pan base diameter is too large, flames can spread out to the sides and damage or burn the worktop, wall claddings or surrounding units and also parts of the hob. The manufacturer cannot be held liable for this type of damage.
- Remember when purchasing new pans that manufacturers usually refer to the diameter at the top of the pan in their documentation.
- Any heat-resistant pans can be used.
- Pans with thick bases are preferable as these distribute heat more evenly. With thin bases, there is a danger of food overheating in places. Stir the food frequently.

- Select pans which are suitable for the burner they are to be used on. In general: use larger diameter pans on the large burners, and smaller diameter pans on the small burners.
- Always place pans on the pan support supplied. Pans must not be placed directly on the burner.
- Place pans securely on the pan rest to minimise the risk of tipping.



- Do not use pots or pans with legs, e.g. dutch ovens.

Energy-saving tips

- Use a pan lid whenever possible to minimise heat loss.
- Cook with as little water as possible.
- Cooking times are greatly reduced when using a pressure cooker.
- Turn the flame down promptly to a lower setting when the pan has come to the boil.

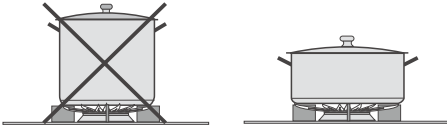

- Wide, shallow pans are preferable to tall, narrow ones. They will heat up faster.

Thermo-electric ignition

This appliance has a thermo-electric ignition safety device. If the flame goes out, for example if food has boiled over or if there is a sudden draught, and automatic re-ignition has been unsuccessful, the supply of gas to the burner will be cut off.

- To use the burner again, turn the control clockwise to the "●" position, and then switch it back on as normal.

Safety cut-out

If a burner has been used for an unusually long period (approx. 4 hours), it will switch off automatically.

To use the burner again, turn the control clockwise to the "●" position, and then switch it back on as normal.

Cleaning and care

Miele offer a range of branded cleaning and conditioning agents for your hob. See "Optional accessories".

 Do not use a steam cleaning appliance to clean this appliance. The steam could reach electrical components and cause a short circuit.

The appliance should be cleaned after each use. Let it cool down to room temperature before cleaning. To avoid water marks and limescale deposits use a soft cloth to dry surfaces that have been cleaned with water.

Cooked food which spills over onto the hot appliance can cause discolouration of the burner components and the stainless steel surface. **Remove any soiling immediately.**

To avoid damaging the surface or your hob, do not use:

- cleaning agents containing soda, alkalines, ammonia, acids or chlorides,
- cleaning agents containing descaling agents,
- stain or rust removers,
- abrasive cleaning agents, e.g. powder cleaners and cream cleaners,
- solvent-based cleaning agents,
- dishwasher cleaner,
- grill and oven cleaners,
- glass cleaning agents,
- hard, abrasive brushes or sponges, e.g. pot scourers, brushes or sponges which have been previously used with abrasive cleaning agents,
- sharp pointed objects (these can damage the seal between the frame and the worktop)
- melamine eraser blocks.

Stainless steel surfaces

Clean stainless steel surfaces using an E-Cloth or with a solution of warm water and a little washing-up liquid applied with a soft sponge. In the case of stubborn dried-on soiling, soak first. Finally, dry with a soft cloth.

If necessary, the pad on the back of a washing-up sponge can be used with Miele cleaning agent for ceramic and stainless steel hobs (see "Optional accessories"). Apply with even pressure following the direction of the "grain".

To help prevent re-soiling, we recommend using Miele stainless steel conditioning agent after cleaning (see "Optional accessories").

Apply sparingly with a soft cloth following the instructions on the packaging.

Printed surfaces (Flame symbols)

Remove any soiling which comes into contact with the printed flame symbols straight away. Soiling, particularly salty food or liquid and olive oil, can cause damage if left on the printed surfaces for a long time.

Do not use the Miele ceramic and stainless steel hob cleaning agent on the printed flame symbols. This would rub off the print.

Pan supports, control knobs

Remove the pan supports. Clean the pan supports and the control knobs with a solution of warm water and a little washing-up liquid applied with a soft sponge. Stubborn soiling should be soaked first.

After cleaning dry all surfaces with a clean cloth.

Do not clean the pan supports in a dishwasher.

Cleaning and care

Burner

Do not clean any parts of the burner in a dishwasher.

The burner should be dismantled and then cleaned by hand using a solution of warm water and a little washing-up liquid applied with a soft sponge.

Parts of the burner that cannot be removed should be wiped clean with a damp cloth only.

The ignitor and ignition safety device should be very carefully wiped clean using a well wrung out cloth.

Do not let the ignitor get wet. If it gets wet it will not spark.

After cleaning dry all surfaces with a clean cloth.

Make sure that the flame slits are clean and completely dry.

The surface of the burner cap will become more matt with time. This is quite normal and will not affect the operation of the hob.

Reassemble the burner

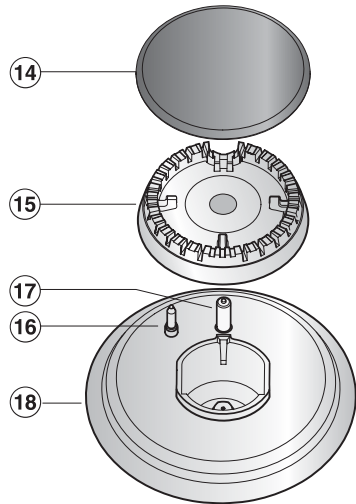

After cleaning the burner it must be reassembled in the correct order.

- Place the burner head ⑮ on to the burner base ⑱ so that the ignition safety device ⑯ and the ignitor ⑰ extend through their respective holes in the burner head. The burner head must click into place correctly.
- Place burner cap ⑭ flat over burner head ⑮. When correctly positioned it will not slide about.

 Repairs to the gas and electrical components of this appliance must only be carried out by a suitably qualified and competent person to ensure safety (Gas Safe registered in the UK). Repairs and other work by unqualified persons could be dangerous. The manufacturer cannot be held liable for unauthorised work.

What to do if ...

... the burner does not ignite when the hob is being used for the first time or after a long period of not being used.

There could be an air lock in the gas pipe. You may need to make several attempts before the burner ignites successfully.

... the in-operation and residual heat indicators are flashing at the same time.

- There has been a power cut.
- Re-ignition was not possible.
- The gas supply has been interrupted.

Turn all the controls clockwise to the "●" position. You can then operate the appliance as normal.

If the problem persists, disconnect the appliance from the electricity supply for a few seconds.

... there has been a power cut.

Turn all the controls clockwise to the "●" position. You can then operate the appliance as normal.

If the problem persists, disconnect the appliance from the electricity supply for a few seconds.

... the burner does not ignite after several attempts.

Disconnect the appliance from the electricity supply for a few seconds. If the problem persists, check whether

- the burner is assembled correctly.
- the gas supply tap is turned on.
- the burner is dry and clean.
- the flame slits are dry and unblocked.

... the gas flame goes out after being lit.

The flames need to touch the ignition safety device so that it heats up sufficiently.

If the flames do not touch the ignition safety device, check that

- the burner components are assembled correctly.
- there is no soiling on the ignition safety device. If there is, remove it carefully (see "Cleaning and care").

Problem solving guide

... the gas flame suddenly looks different.

Check whether the burner components are assembled correctly.

... the gas flame goes out during operation.

Check whether the burner components are assembled correctly.

.... the ignitor on the burner does not spark.

Check whether

- the mains fuse has tripped. If it has, contact a qualified electrician or the Miele Service Department.
- food deposits have lodged themselves between the ignitor and the burner cap.
Remove any food deposits carefully (see "Cleaning and care").
- food deposits have lodged themselves on the ignition safety device.
Remove any food deposits carefully (see "Cleaning and care").

For safety reasons you may not be able to re-ignite the burner for about 5 minutes after a spillage.

Optional accessories

Miele offer a comprehensive range of useful accessories as well as cleaning and conditioning products for your Miele appliances.

These can be ordered online at:



or from Miele (see back cover for contact details)

Ceramic and stainless steel hob cleaner 250 ml



Removes heavy soiling, limescale deposits and light discolouration

Stainless steel conditioning agent 250 ml



Removes water marks, flecks and fingerprints.
Helps prevent re-soiling.

E-cloth (microfibre cloth)

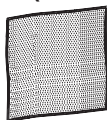

Removes fingerprints and light soiling.

Safety instructions for installation

This appliance must be installed and connected to services in accordance with local and national safety and building regulations.

To avoid the risk of damaging the hob fit the wall units and extractor hood before installing it.

▶ The room in which the gas hob is installed must be at least 20 m³ in size with a door or window in it which can be opened to the outside air.

▶ The veneer or laminate coatings of worktops (or adjacent kitchen units) must be treated with 100 °C heat-resistant adhesive which will not dissolve or distort.
Any backmoulds must be of heat-resistant material.

▶ This appliance must not be used in a non-stationary location (e.g. on a ship).

▶ An electric fryer must not be installed directly next to a gas hob, as the gas flames could ignite the fat in the fryer. It is essential to maintain a distance of at least 288 mm between these two appliances.

▶ A gas hob must not be installed above a fridge, fridge freezer, freezer, dishwasher, washing machine or tumble dryer.

▶ The hob may only be installed above a Miele oven if the worktop is at least 40 mm thick.

▶ Ensure that the gas pipe and electrical cable are installed in such a way that they do not touch any parts of the appliance which become hot. This could cause damage.

▶ The electrical cable and any flexible gas connection pipe must be installed in such a way so that they do not come into contact with any moving kitchen parts (e.g. a drawer), and cannot become trapped.

▶ Observe carefully the safety distances given on the following pages.

All dimensions in this instruction booklet are given in mm.

Safety distance above the appliance

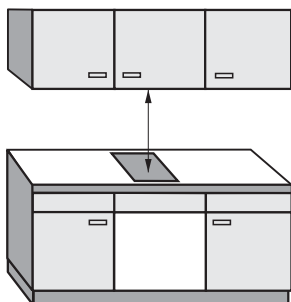

A minimum safety distance must be maintained between the appliance and the cooker hood above it. See the cooker hood manufacturer's operating and installation instructions for details.

If the manufacturer's instructions are not available for the cooker hood, a minimum safety distance of at least 760 mm must be maintained. For any flammable objects, e.g. utensil rails, wall units etc. a minimum distance of at least 760 mm must be maintained between them and the appliance below.

When two or more appliances are installed together below a cooker hood, e.g. an electric hob and a gas wok combiset, which have different safety distances given in their installation instructions you should select the greater distance of the two.

Safety instructions for installation

Safety distances to the sides of the hob

Ideally the hob should be installed with plenty of space on either side. There may be a wall at the rear and a tall unit or wall at one side. On the other side, however, no unit or divider should stand higher than the hob (see illustrations).

Due to the high temperatures radiated by the appliance, it is essential that a minimum distance of **50 mm** is maintained between the worktop cut-out and the back wall.

The following minimum distance ① between the worktop cut-out and a wall or tall unit to the right or left of it must be maintained:

40 mm for CS 1212 / CS 1212-1
CS 1221 / CS 1221-1
CS 1222
CS 1223
CS 1234 / CS 1234-1

50 mm for CS 1112
CS 1122
CS 1134
CS 1326
CS 1327
CS 1411

100 mm for CS 1012 / CS 1012-1

150 mm for CS 1421
CS 1312
CS 1322

200 mm for CS 1034 / CS 1034-1

250 mm for CS 1011
CS 1021

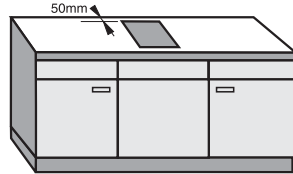

Recommended

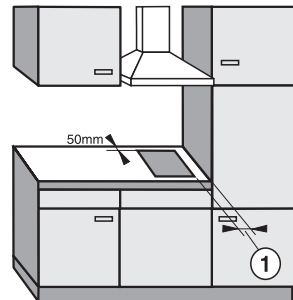

Not recommended

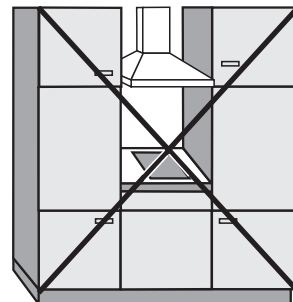

Not allowed

Safety instructions for installation

Safety distance when installing the appliance near a wall with additional niche cladding

A minimum safety distance must be maintained between the worktop cut-out and any niche cladding to protect it from heat damage.

If the niche cladding is made from a **combustible material** (e. g. wood) a minimum safety distance ⑤ of 50 mm must be maintained between the cut-out and the cladding.

If the niche cladding is made from a **non-combustible material** (e. g. metal, natural stone, ceramic tiles) a minimum safety distance ⑤ of 50 mm less the thickness of the cladding must be maintained between the cut-out and the cladding.

Example: 15 mm niche cladding

50 mm - 15 mm = minimum safety distance of 35 mm

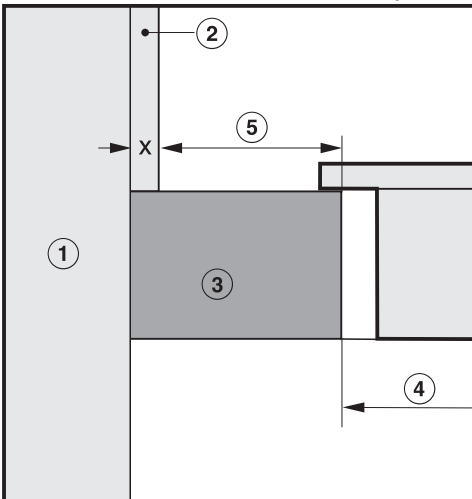

① Masonry

② Niche cladding

Dimension x = thickness of niche cladding material

③ Worktop

④ Worktop cut-out

⑤ Minimum safety distance

for **combustible** materials is 50 mm

for **non-combustible** materials is 50 mm less dimension x

Appliance and building-in dimensions

CS 1012-1

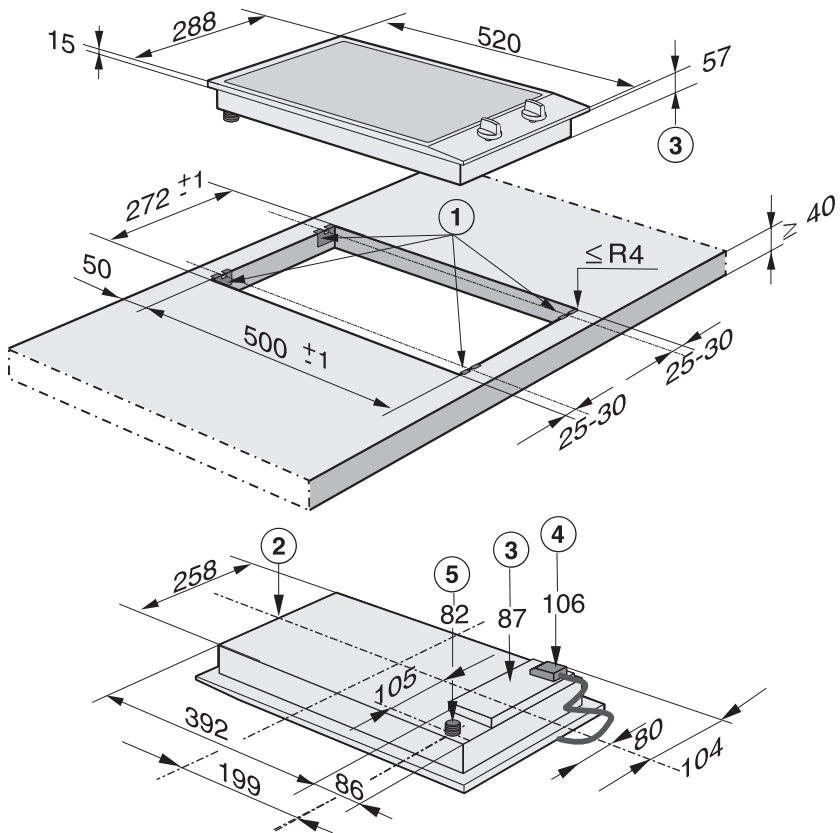

- ① Spring clamps
- ② Front
- ③ Casing depth
- ④ Casing depth including the mains connection box with mains connection cable,
L = 1440 mm
- ⑤ Casing depth including the gas connection R 1/2 - ISO 7-1 (DIN EN 10226)

Appliance and building-in dimensions

CS 1034-1

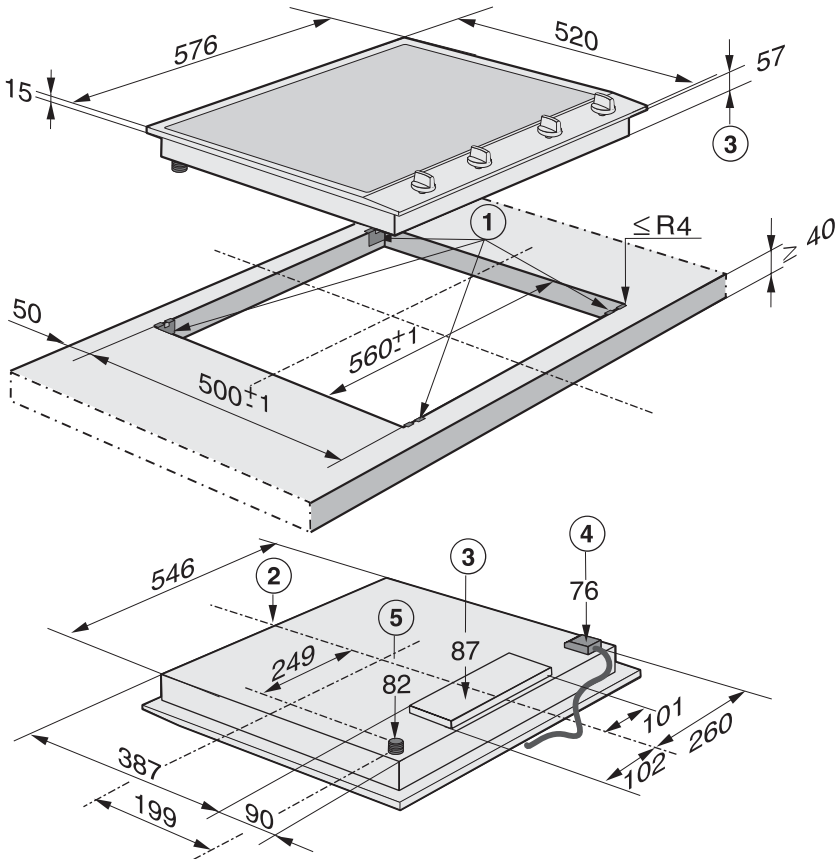

- ① Spring clamps
- ② Front
- ③ Casing depth
- ④ Casing depth including the mains connection box with mains connection cable, L = 1440 mm
- ⑤ Casing depth including the gas connection R 1/2 - ISO 7-1 (DIN EN 10226)

Preparing the worktop

- Make the worktop cut-out for one or more appliances in accordance with the building-in diagrams. Remember to maintain the **minimum safety distance** from the **back wall**, as well as from any **tall unit or side wall** to the right or left of the hob. See "Safety instructions for installation".
- Seal the cut surfaces with a suitable heat-resistant sealant to avoid swelling caused by moisture.

If, during installation, you find that the seals on the corners of the frame are not flush with the worktop surface, the corner radius ($\leq R4$) can be carefully scribed to fit.

Installation of several appliances

When installing two or more appliances next to each other a spacer bar ② must be used between each one.

See "Fixing the spring clamps and spacer bars".

Worktop cut-out - two appliances

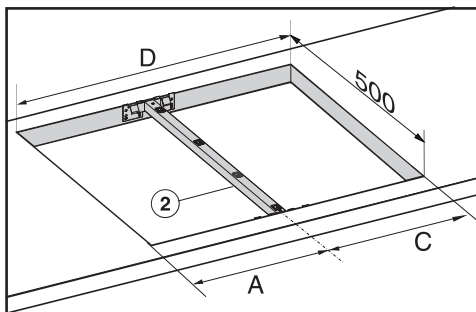

Worktop cut-out - three appliances

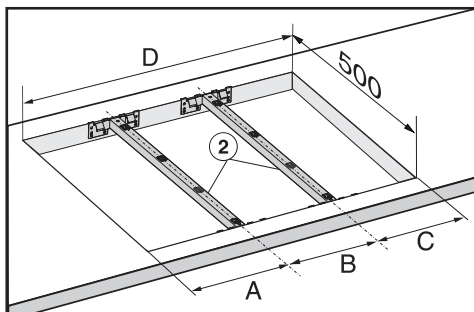

To calculate the cut-out width (D) required:

Add up the widths of each appliance (e.g. 288 mm, 380 mm) and subtract 16 mm from this figure

Number of appliances	Appliance width in mm	Worktop cut-out in mm
1	288	$288 - 16 = \mathbf{272}$
2	288, 288	$288 + 288 - 16 = \mathbf{560}$
2	288, 380	$288 + 380 - 16 = \mathbf{652}$
3	288, 288, 288	$288 + 288 + 288 - 16 = \mathbf{848}$
3	288, 288, 380	$288 + 288 + 380 - 16 = \mathbf{940}$

Installation of several appliances

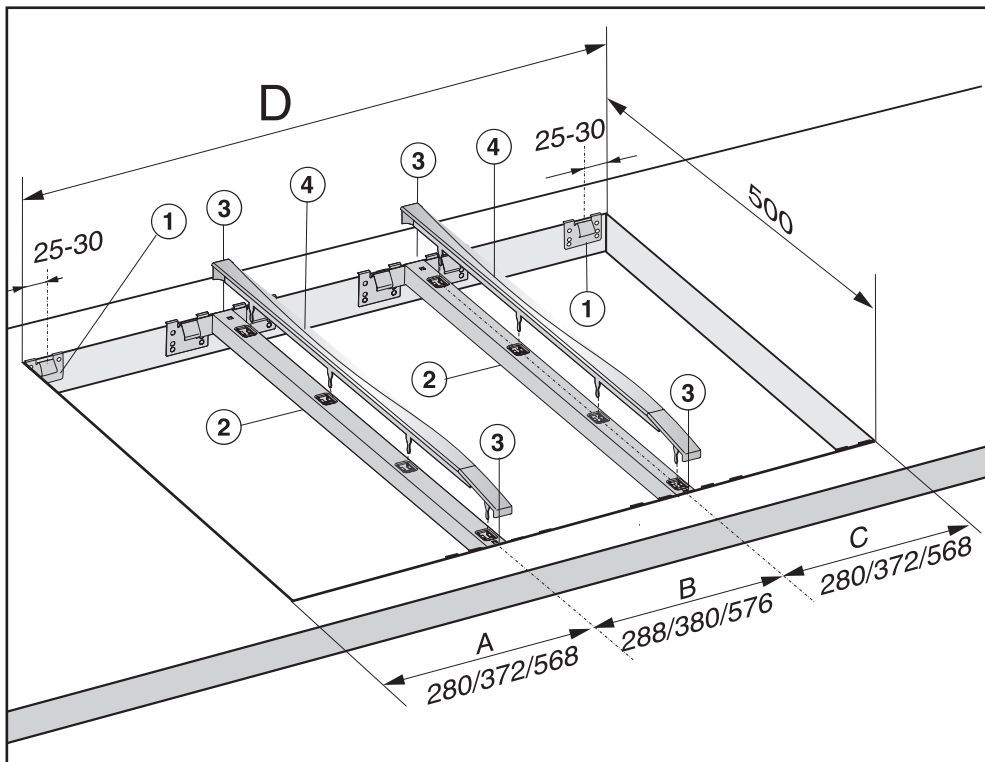

- ① Spring clamps
- ② Spacer bars
- ③ Gaps between spacer bars and worktop
- ④ Cover strips

The illustration shows a worktop cut-out with spring clamps ① and spacer bars ② for 3 appliances.

An additional spacer bar is required for each additional appliance. The position for securing each additional spacer bar will depend on the width of appliance **B** (288 mm / 380 mm / 576 mm).

Fixing the spring clamps and spacer bars

Wooden worktops

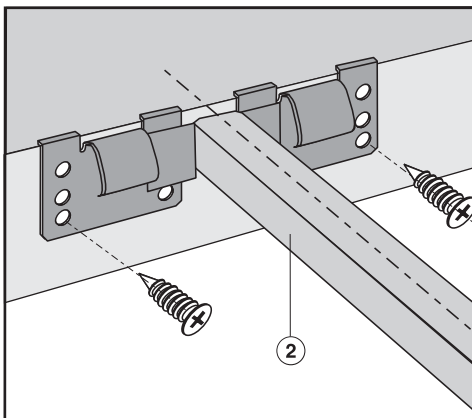
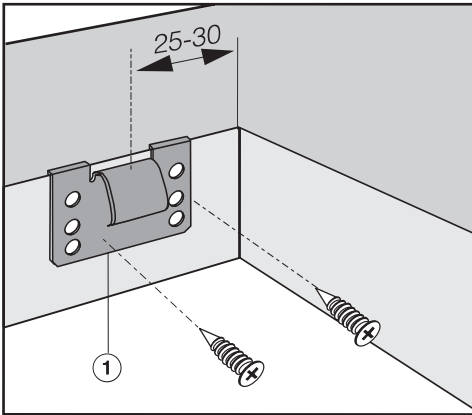

- Position the spring clamps supplied ① and spacer bars ② on the top edge of the cut-out in the positions marked.
- Secure the spring clamps and spacer bars with the 3.5 x 25 mm screws supplied.

Fixing the spring clamps and spacer bars

Granite and marble worktops

The screws are not required for granite or marble worktops.

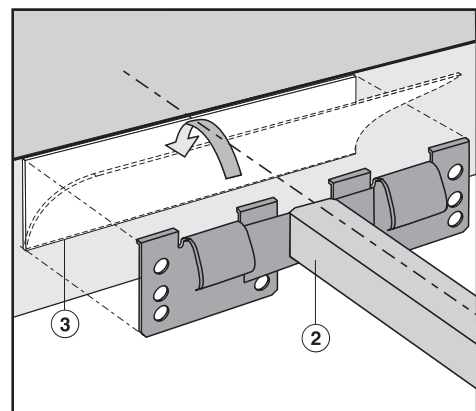
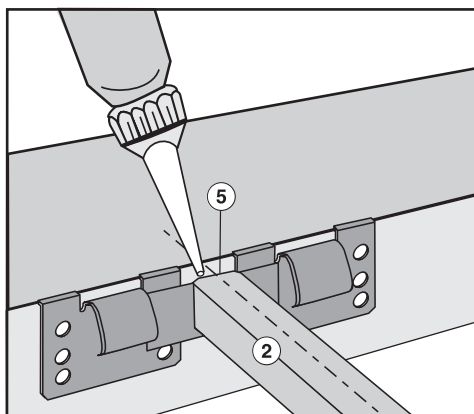
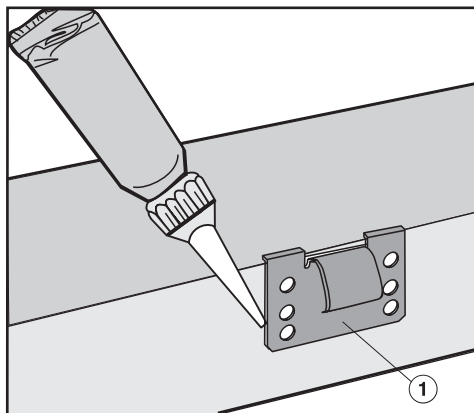
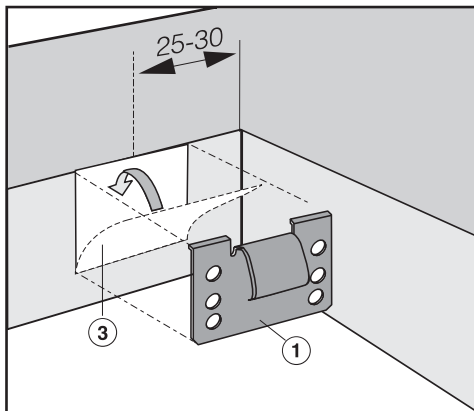

- Position and secure the spring clamps ① and spacer bars ② using strong, double-sided adhesive tape ③.

- Apply silicone to the side edges and the lower edges of spring clamps ① and spacer bars ②.
- Then fill gap ⑤ between the spacer bars and the worktop with silicone.

Installing / removing the appliance

Installing the appliance

- Feed the connection cable down through the cut-out.
- Starting at the front, position the appliance in the worktop cut-out.
- Using both hands, press down evenly on the sides of the appliance until it clicks into position. When doing this make sure that the seal under the appliance sits flush with the worktop on all sides. This is important to ensure an effective seal all round. **Do not use sealant.**
- Push the appliance to the side until the holes in the spacer bar can be seen.

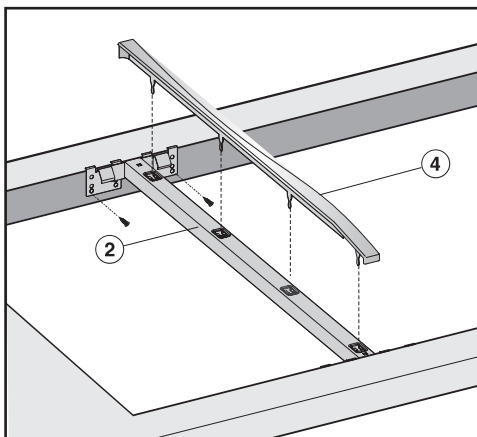

- Fit the cover strip ④ into the holes in the spacer bar ②.

- Starting at the front, position the next appliance in the worktop cut-out.
- Connect the appliance(s) to the mains (see "Electrical connection") and to the gas supply (see "Gas connection").
- Check that the appliance(s) work(s).

Removing the appliance

If the appliance is **accessible underneath**, it can be pushed up out of the cut-out from below. It must be pushed up from the back first.

If the appliance is **not accessible underneath**, take hold of the appliance with both hands at the back, pull it forwards, then lift it up and out.

General installation tips

Seal between the appliance and the worktop

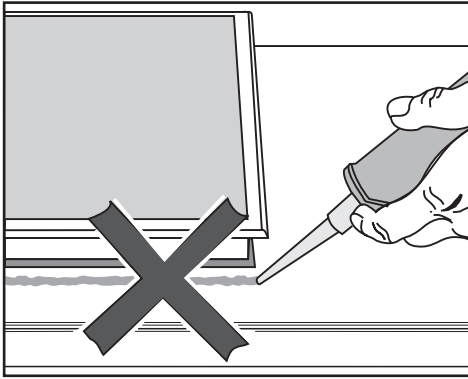

The sealing strip under the edge of the top part of the appliance provides a sufficient seal for the worktop.

The appliance must not be sealed with sealant (e.g. silicone). This could result in damage to the appliance or the worktop if it ever needs to be removed for servicing.

Tiled worktop

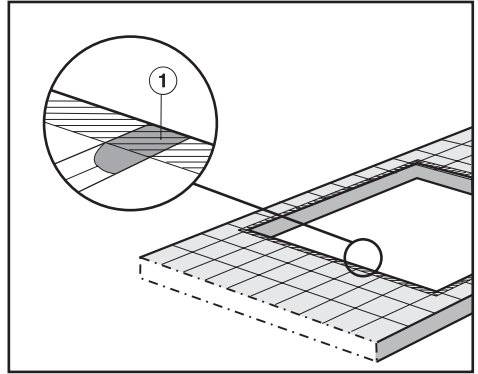

Grout lines ① and the hatched area underneath the surface of the appliance must be smooth and even. If they are not, the appliance will not sit flush with the worktop and the sealing strip underneath the top part of the appliance will not provide a good seal between the appliance and the worktop.

All electrical work should be carried out by a suitably qualified and competent person in strict accordance with current local and national safety regulations (BS 7671 in the UK).

If the connection cable is damaged, it must be replaced by a suitably qualified electrician with a special connection cable of type H 05 V V-F (pvc insulated), available from Miele.

Installation, repairs and other work by unqualified persons could be dangerous. The manufacturer cannot be held liable for unauthorised work.

Ensure power is not supplied to the appliance until after installation or repair work has been carried out.

The appliance must only be operated when built-in. This is to ensure that all electrical parts are shielded. Live parts must not be exposed.

Do not connect the appliance to the mains electricity supply by an extension lead. These do not guarantee the required safety of the appliance.

Connection should be made via a fused plug and switched socket or a double pole fused spur connection unit, or a suitable isolator (as appropriate) which complies with national and local safety regulations and the on/off switch should be easily accessible after the appliance has been built in.

If the switch is not accessible after installation (depending on country) an additional means of disconnection must be provided for all poles.

For extra safety it is advisable to protect the appliance with a suitable residual current device (RCD).

When switched off there must be an all-pole contact gap of at least 3 mm in the isolator switch (including switch, fuses and relays).

Important U.K.

The appliance is supplied for connection to a 230-240 V, 50 Hz supply with a 3-core cable.

The wires in the mains lead are coloured in accordance with the following code:

Green/yellow	= earth
Blue	= neutral
Brown	= live

WARNING
THIS APPLIANCE MUST BE
EARTHED

Please make sure that the connection data quoted on the data plate match the household mains supply.

Electrical connection

Important

The electrical safety of this appliance can only be guaranteed when continuity is complete between it and an effective earthing system, which complies with current local and national safety regulations. It is most important that this basic safety requirement is present and regularly tested and where there is any doubt, the electrical wiring in the home should be tested by a qualified electrician. The manufacturer cannot be held liable for the consequences of an inadequate earthing system such as an electric shock.

The manufacturer cannot be held liable for damage which is the direct or indirect result of incorrect installation or connection.

 Connection to the gas supply, or conversion from one type of gas to another, should only be undertaken by an approved and registered gas installer in strict accordance with local and national safety and building regulations (e.g. Gas Safe registered in the UK).

Every appliance should have its own easily accessible isolating valve and test point.

Check with your local gas supplier about the type of gas and its calorific value and compare this information with the type of gas quoted on the hob data plate.

This appliance is not connected to an exhaust flue. Please ensure it has adequate ventilation after installation.

The installer is responsible for ensuring that the appliance functions correctly when installed.

Depending on country, the hob is supplied ready for connection to natural or liquid gas (refer to label on the appliance).

United Kingdom:
GB II 2 H 3+ 20 mbar, 28-30/37 mbar

Ireland:
IE II 2 H 3+ 20 mbar, 28-30/37 mbar

Depending on country, a set of jets for conversion to an alternative type of gas may be included with the hob.

Please contact your dealer or the Miele Spare Parts Department for the appropriate conversion jets if necessary.

Conversion to another type of gas is described under "Conversion to another type of gas".

For any gas work in the UK always use a Gas Safe registered engineer.



Gas connection

Connection

The gas connection must be installed so that connection can be made either from inside or outside the kitchen unit, and the isolating valve must be easily accessible and visible (by opening one of the kitchen doors, if necessary).

After installing the appliance the gas burners have to be set for local conditions.

When the gas hob has been installed, it is essential to check that neither the gas pipe nor the electricity cable is in contact with hot parts of the appliance or hot gas exhaust, otherwise heat damage to the pipe and cable could occur.

A test for possible leakages must be carried out after installation.

Safety regulations demand that a pressure test point is installed near a gas hob to allow an engineer to test the pressure, following servicing.

The appliance is supplied with an R 1/2" - ISO 7-1 (DIN EN 10226) gas connection point.

An appropriate rigid connection and isolating valve must be installed for final connection.

The gas connection must be so sited that it is not adversely heated when the appliance is in operation.

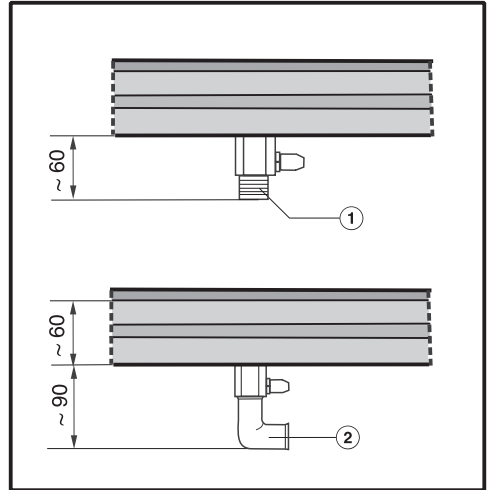

- ① Connection with test point specifically for GB
- ② Connection with test point specifically for GB and 90° angle

Conversion to another type of gas

 Connection to the gas supply, or conversion from one type of gas to another, should only be undertaken by an approved and registered gas installer in strict accordance with local and national safety and building regulations (e.g. Gas Safe registered in the UK).

When converting to a different type of gas, the main jets and the small jets have to be changed.

CS 1012-1

Nominal rating at high setting

	Gas type	kW
Medium burner	Natural gas H	1.80
	Liquid gas	1.80 / 131 g/h
Large burner	Natural gas H	3.00
	Liquid gas	3.00 / 218 g/h
Total output	Natural gas H	4.80
	Liquid gas	4.80 / 349 g/h

Nominal rating at low setting

	Gas type	kW
Medium burner	Natural gas H	0.35
	Liquid gas	0.35
Large burner	Natural gas H	0.50
	Liquid gas	0.50

Screw in the new jets according to the following table.

Jet table

For UK and IE

	Main jet ∅	Small jet ∅
Natural gas H		
Medium burner	1.00	0.42
Large burner	1.28	0.52
Liquid gas		
Medium burner	0.67	0.27
Large burner	0.87	0.32

The jet markings refer to 1/100 mm of the jet diameter.

Conversion to another type of gas

CS 1034-1

Nominal rating at high setting

	Gas type	kW
Small burner	Natural gas H	1.00
	Liquid gas	1.00 / 73 g/h
Medium burner	Natural gas H	1.80
	Liquid gas	1.80 / 131 g/h
Large burner	Natural gas H	3.00
	Liquid gas	3.00 / 218 g/h
Total output	Natural gas H	8.80
	Liquid gas	8.80 / 640 g/h

Nominal rating at low setting

	Gas type	kW
Small burner	Natural gas H	0.25
	Liquid gas	0.25
Medium burner	Natural gas H	0.35
	Liquid gas	0.35
Large burner	Natural gas H	0.50
	Liquid gas	0.50

Screw in the new jets according to the following table.

Jet table

For UK and IE

	Main jet Ø	Small jet Ø
Natural gas H		
Small burner	0.76	0.39
Medium burner	1.00	0.42
Large burner	1.28	0.52
Liquid gas		
Small burner	0.50	0.23
Medium burner	0.67	0.27
Large burner	0.87	0.32

The jet markings refer to 1/100 mm of the jet diameter.

Conversion to another type of gas

Changing the jets

Disconnect the gas hob from the mains electricity supply. Turn off the gas supply.

To change the main jets

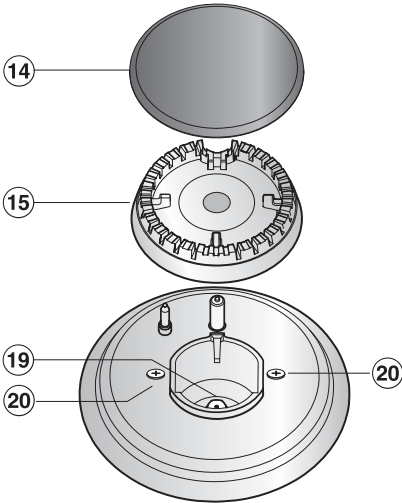

- Remove the pan support, burner cap ⑭ and burner head ⑮.
- Using an M7 socket spanner, unscrew main jet ⑲.
- Change the main jet.

To change the small jets

The upper section of the appliance has to be removed before the small jets can be changed.

- Remove burner cap ⑭ and burner head ⑮.
- Pull the control knobs off.
- Loosen screws ⑳.

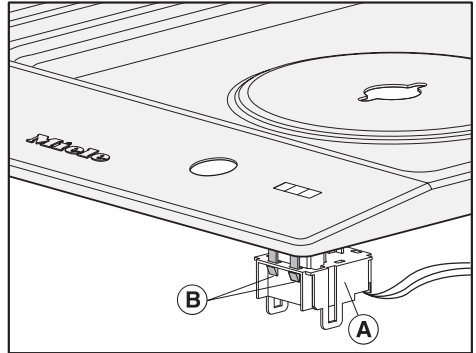

- Carefully remove the upper section of the appliance. When doing this make sure you do not also pull out the light unit for the display A located underneath the upper section. To release the unit, squeeze together the two clamps B.

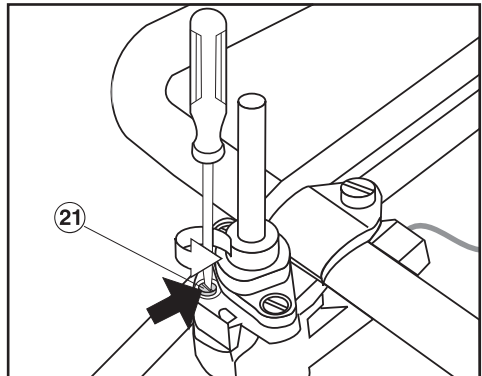

- Using a small screwdriver, unscrew small jet ㉑ in the gas fitting.
- Pull out the jet with a pair of pliers.
- Fit the correct jets securely (see jet table).
- Finally, secure the jets against inadvertent loosening with sealing wax.

Conversion to another type of gas

Function test

Check all gas fittings for leaks.

- Reassemble the appliance.
- Check the burner flame by operating the burner.

The flame must not go out on the lowest setting, or when the control is turned quickly from a high to a low setting.

On the highest setting, the flame must have a distinctive and visible core.

- Stick the label supplied with the jets above the label stating the type of gas being used.

After sales service, data plate, guarantee

In the event of any faults which you cannot remedy yourself, or if the appliance is under guarantee, please contact:

- Your Miele dealer, or
- the Miele Service Department (see back cover for address).

Please note that telephone calls may be monitored and recorded to improve our service.

When contacting Miele, please quote the model and serial number of your appliance which are given on the data plate.

N.B. A call-out charge will be applied for service visits where the problem could have been resolved as described in these instructions.

Space in which to stick the extra data plate supplied with the appliance. Ensure that the model number is the same as the one on the front of these instructions.

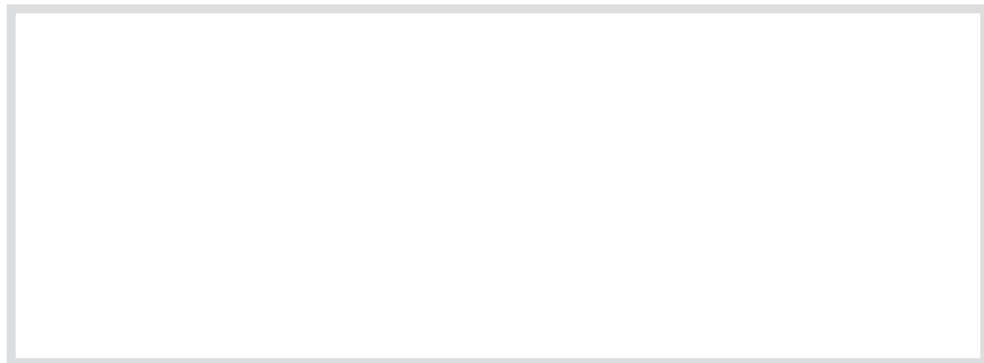

Guarantee

For information on the appliance guarantee specific to your country please contact Miele. See back cover for contact details.

In the U.K. your appliance is guaranteed for 2 years from the date of purchase. However, you must activate your cover by calling 0845 365 6640 or registering online at www.miele.co.uk

United Kingdom

Miele Co. Ltd.
Fairacres, Marcham Road
Abingdon, Oxon, OX14 1TW
Tel: 0845 365 0555
Fax: 0845 365 0777
Customer Contact Centre Tel: 0845 365 6600
E-mail: info@miele.co.uk
Internet: www.miele.co.uk

Australia

Miele Australia Pty. Ltd.
ABN 96 005 635 398
1 Gilbert Park Drive, Knoxfield, VIC 3180
Tel: (03) 9764 7130, Fax: (03) 9764 7149
Internet: www.miele.com.au

China

Miele (Shanghai) Trading Ltd.
1-3 Floor, No. 82 Shi Men Yi Road
Jing' an District
200040 Shanghai, PRC
Tel: +86 21 6157 3500
Fax: +86 21 6157 3511
E-mail: miele Shanghai@cn.miele.com
Internet: www.miele.cn

Miele (Hong Kong) Limited

41/F - 4101, Manhattan Place
23 Wang Tai Road
Kowloon Bay
Hong Kong
Tel: (852) 2610 1331
Fax: (852) 2610 1013
Email: mielehk@miele.com.hk

India

Miele India Pvt. Ltd.
Ground Floor, Copia Corporate Suites
Plot No. 9, Jasola
New Delhi - 110025
Tel: 011-46 900 000, Fax: 011-46 900 001
E-mail: customercare@miele.in
Internet: www.miele.in

Manufacturer: Germany - Miele & Cie. KG
Carl-Miele-Straße 29, 33332 Gütersloh



Ireland

Miele Ireland Ltd.
2024 Bianconi Avenue
Citywest Business Campus, Dublin 24
Tel: (01) 461 07 10, Fax: (01) 461 07 97
E-Mail: info@miele.ie, Internet: www.miele.ie

New Zealand

Miele New Zealand Limited
Unit L, 10-20 Sylvia Park Road
Mt. Wellington, 1060, Auckland, NZ
Tel: 0800 264 353, Fax: 0800 463 453
Internet: www.miele.co.nz

Singapore

Miele Southeast Asia
Miele Pte. Ltd.
163 Penang Road
04 - 02/03 Winsland House II
Singapore 238463
Tel: +65 6735 1191, Fax: +65 6735 1161
E-Mail: infosea@miele.com.sg
Internet: www.miele.sg

South Africa

Miele (Pty) Ltd
63 Peter Place, Bryanston 2194
P.O. Box 69434, Bryanston 2021
Tel: +27 (0) 11 548-1900
Fax: +27 (0) 11 548-1935
E-mail: info@miele.co.za
Internet: www.miele.co.za

United Arab Emirates

Miele Appliances Ltd.
P.O. Box 11 47 82
Gold & Diamond Park
Sheikh Zayed Road
Building 6 / Offices Nos. 6-214 to 6-220
Dubai
Tel: +971-4-341 84 44
Fax: +971-4-341 88 52
E-Mail: info@miele.ae
Internet: www.miele.ae